

Basic Instructions for Installation of Permaglass FRP PUMP COLUMN

Permaglass FRP PUMP COLUMN is coupled using the Kwik-Lok joint which consists of an O'ring for pressure sealing and a 316 Stainless Steel Locking Cable. Permaglass FRP PUMP COLUMN has an Anti-Torque Octagonal male end to stop rotation of the pipe joint with pump thrust. 316 grade stainless steel connectors are threaded one end for pump and head works, the other end is a machined Permaglass male for connecting into the double ended female (bottom) and standard female (top).

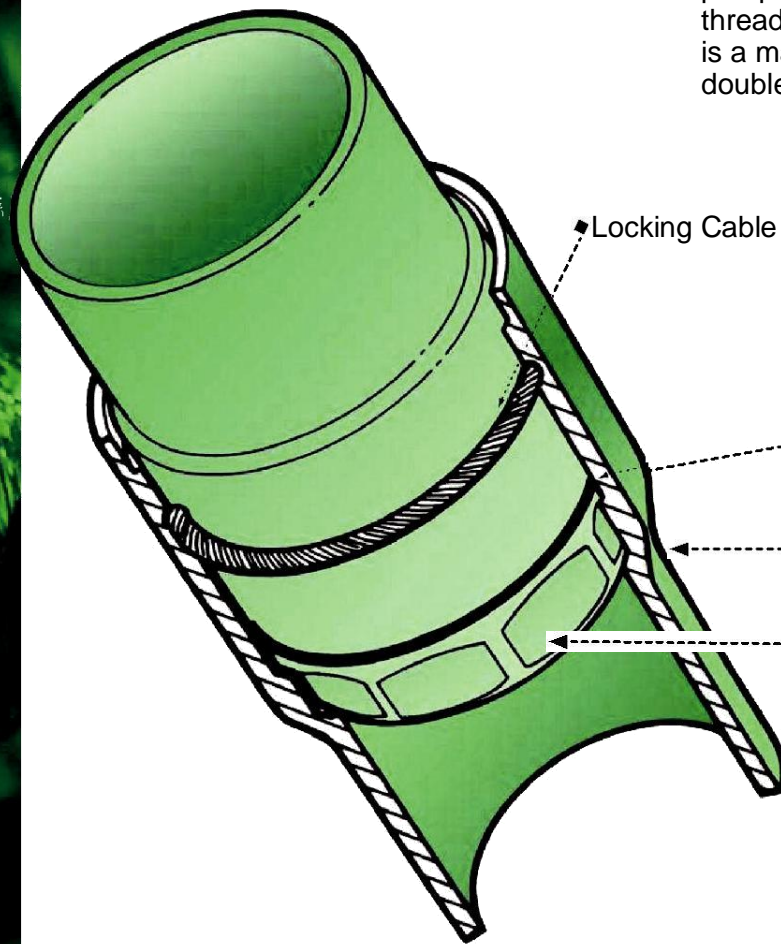

Locking Cable groove - Ensure groove is clean before inserting Cable
Lubricate and insert Locking Cable through
until inserted end has visibly passed right
round the pipe circumference in the groove

O'ring Groove - Apply suitable lubricant to installed
O'ring

Fit lifting clamps under female "Bell" (or collar)
or bottom stainless steel connector

Anti-torque hexagonal Joint

Wrap PERMATAPE duct tape around
inserted locking cable and pipe join to
ensure cable end is secured flat and
silt buildup in the joint is prevented.

Fibreglass Reinforced Plastic (FRP/GRP) or GRE are all material names for "Fibreglass" Pipe. Permaglass FRP PUMP COLUMN is high quality Fibreglass Pipe which has been used in Australian (and overseas) pump installations for over 25 years. Permaglass is made to Australian Standards and also incorporates Testing and Post Curing to ensure the highest quality and strength is achieved.



Manufactured by RPC Technologies Pty Ltd

Distributed by WBS Pumps Pty Ltd
6A La Salle Street, Dudley Pk. S.A. 5008

Tel. 08 8344 9927
Fax 08 8344 9925



FIGHT CORROSION AND WATER CONTAMINATION WITH

PERMAGLASS FRP PUMP COLUMN

INCLUDES NEW HEAVY DUTY SPECIFICATIONS

FITTINGS, ADAPTERS AND SPARES

- Lifting clamps (Certified)
- FLANGES
- REDUCERS
- END CONNECTERS, FLANGES and REDUCERS
316L stainless steel (standard) or Duplex by request
- DRAIN PLUGS
- LOCKING WIRES & O-RINGS AVAILABLE AS SPARES

BSP Threads are used on all threaded adapters unless requested otherwise (price may vary for alternative thread types)

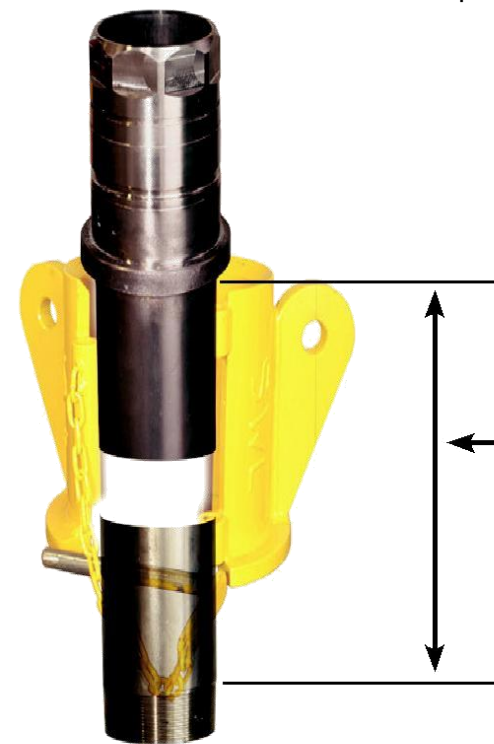

Exposed Length of Connector
(Allow 2 in overall Length)

Size	Length mm	Weight kgs
DN80	200	5
DN100	250	8
DN125	260	10
DN150	310	17
DN200	350	28



Permaglass FRP PUMP COLUMN is a lightweight, rigid rising main designed for submersible pump installations. It will not corrode like steel and is very quick and easy to install. Permaglass FRP PUMP COLUMN is suitable for pump settings nominally to 200 meters (standard duty) and 350 meters (heavy duty) - more in some instances, contact supplier. Please check the maximum tensile load to select the correct Permaglass FRP PUMP COLUMN to suit your application.

FEATURES:

- KWIK-LOK JOINTS (very quick and easy to join)
- ANTI-TORQUE NON ROTATING JOINTS
- LIGHTWEIGHT COLUMN
- CORROSION RESISTANT FRP

BENEFITS:

- FAST INSTALLATION AND REMOVAL (by a team of 2)
- LONG SERVICE LIFE - REUSE OVER MANY YEARS
- EASY TO ADD LENGTH AS WATER TABLE FALLS
- RIGID DESIGN, DOES NOT STRETCH, EXPAND OR TWIST CAUSING POTENTIAL FAILURE OF ELECTRICAL CABLES IN THE BORE

Permaglass FRP PUMP COLUMN Technical Data

Standard duty (nominal depth 200 meters) New heavy duty (nominal depth 350 meters)
Deeper applications may apply depending on load (contact supplier)

Size	Internal Diameter	OD at Coupling	Standard Wall Thickness	Locking Cord Diameter	Weight	Maximum Equivalent Tensile Load*	Maximum Allowable Torque	Maximum Allowable Internal Pressure
	mm(in.)	mm	mm	mm	kg/m	kg	kg.m	kPa
75SD	76(3)	112	5	6	2.1	3580	40	6430
75HD	76(3)	112	6.5	6	2.7	4630	56	8420
100SD	101.7(4)	143	5	6	2.8	6390	71	4875
100HD	101.7(4)	143	8	6	4.5	8070	125	7905
125SD	127.1(5)	169	6.5	6	4.6	8110	151	5190
125HD	127.1(5)	169	9.5	6	6.7	9850	235	7610
150SD	152.5(6)	202	6.5	8	5.5	11340	215	4355
150HD	152.5(6)	202	9.5	8	8	14250	334	6415
200SD	203(8)	267	8	10	8.9	14840	479	4100
200HD	203(8)	267	11	10	12.3	18920	688	5660

- *Tensile load = axial stress due to the combination of internal pressure, weight of pump & motor, electrical cable, shutoff head, column and water in the column
- Refer to supplier if uncertain of load calculation or should load exceed maximum load
- Effective lengths available - 5m (standard), 3m, 2m, 1m
- Handles 80°C up to 100°C with reference to supplier over 80°C
- Suitable for potable water
- Locking wires in 316 stainless steel (standard) special plastic cord for highly corrosive water (refer supplier)